

ADuM1100AR/ADuM1100BR*

FEATURES

High Data Rate: DC –100 Mbps (NRZ)
Compatible with 3.3 V/3.3 V or 5.0 V/5.0 V Operation
Low-Power Operation

5 V Operation:

1.0 mA Max @ 1 Mbps
4.5 mA Max @ 25 Mbps
16.8 mA Max @ 100 Mbps

3.3 V Operation:

0.4 mA Max @ 1 Mbps
3.5 mA Max @ 25 Mbps
7.1 mA Max @ 50 Mbps

Small Footprint: Standard 8-Lead SO Package

High Common-Mode Transient Immunity: >25 kV/μs

Safety and Regulatory Approvals

UL Recognized

2500 V RMS for 1 Min per UL 1577

CSA Component Acceptance Notice #5A

VDE 0884

$V_{IORM} = 560 V_{PEAK}$

APPLICATIONS

Digital Fieldbus Isolation

Opto-Isolator Replacement

Computer-Peripheral Interface

Microprocessor System Interface

General Instrumentation and Data Acquisition Applications

DESCRIPTION

The ADuM1100AR and ADuM1100BR are digital isolators based on Analog Devices' *iCoupler*™ technology. Combining high-speed CMOS and monolithic air core transformer technology, these isolation components provide outstanding performance characteristics superior to alternatives such as optocoupler devices.

Configured as pin-compatible replacements for existing high-speed optocouplers, the ADuM1100AR and ADuM1100BR support data rates as high as 25 Mbps and 100 Mbps, respectively.

Both the ADuM1100AR and ADuM1100BR operate at either 3.3 V or 5 V supply voltages, boast propagation delay of <18 ns and edge asymmetry of <2 ns (at 5 V operation). They operate at very low power, less than 0.9 mA of quiescent current (sum of both sides), and a dynamic current of less than 160 μA per Mbps of data rate. Unlike common transformer implementations, the ADuM1100AR/ADuM1100BR provides dc correctness with a patented refresh feature that continuously updates the output signal.

FUNCTIONAL BLOCK DIAGRAM

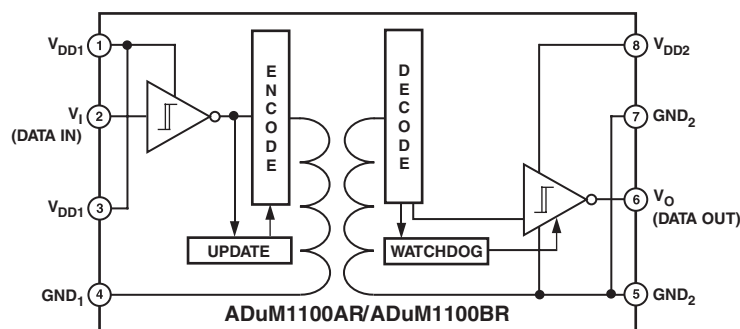

NOTE
 FOR PRINCIPLES OF OPERATION, SEE METHOD OF OPERATION,
 DC CORRECTNESS, AND MAGNETIC FIELD IMMUNITY SECTION
 OF THIS DATA SHEET.

*Protected by U.S. Patent 5,952,849. Additional patents are pending.
iCoupler is a trademark of Analog Devices, Inc.

REV. 0

Information furnished by Analog Devices is believed to be accurate and reliable. However, no responsibility is assumed by Analog Devices for its use, nor for any infringements of patents or other rights of third parties that may result from its use. No license is granted by implication or otherwise under any patent or patent rights of Analog Devices.

One Technology Way, P.O. Box 9106, Norwood, MA 02062-9106, U.S.A.
Tel: 781/329-4700 www.analog.com
Fax: 781/326-8703 © Analog Devices, Inc., 2001

ADuM1100AR/ADuM1100BR—SPECIFICATIONS

ELECTRICAL SPECIFICATIONS, 5 V OPERATION¹ (4.5 V ≤ V_{DD1} ≤ 5.5 V, 4.5 V ≤ V_{DD2} ≤ 5.5 V. All Min/Max specifications apply over the entire recommended operation range unless otherwise noted. All typical specifications are at T_A = 25°C, V_{DD1} = V_{DD2} = 5 V.)

| Parameter | Symbol | Min | Typ | Max | Unit | Test Conditions |
|---|-----------------------|------------------------|------|------|-------|--|
| DC SPECIFICATIONS | | | | | | |
| Input Supply Current | I _{DD1(Q)} | | 0.3 | 0.8 | mA | V _I = 0 V or V _{DD1} |
| Output Supply Current | I _{DD2(Q)} | | 0.01 | 0.06 | mA | V _I = 0 V or V _{DD1} |
| Input Supply Current (25 Mbps) (See TPC 1.) | I _{DD1(25)} | | 2.2 | 3.5 | mA | 12.5 MHz Logic Signal Frequency |
| Output Supply Current ² (25 Mbps) (See TPC 2.) | I _{DD2(25)} | | 0.5 | 1.0 | mA | 12.5 MHz Logic Signal Frequency |
| Input Supply Current (100 Mbps) (See TPC 1.) | I _{DD1(100)} | | 9.0 | 14 | mA | 50 MHz Logic Signal Frequency, ADuM1100B Only |
| Output Supply Current ² (100 Mbps) (See TPC 2.) | I _{DD2(100)} | | 2.0 | 2.8 | mA | 50 MHz Logic Signal Frequency, ADuM1100B Only |
| Input Current | I _I | -10 | 0.01 | +10 | μA | 0 ≤ V _{IN} ≤ V _{DD1} |
| Logic High Output Voltage | V _{OH} | V _{DD2} - 0.1 | 5.0 | | V | I _O = -20 μA, V _I = V _{IH} |
| | | V _{DD2} - 0.8 | 4.6 | | | I _O = -4 mA, V _I = V _{IH} |
| Logic Low Output Voltage | V _{OL} | | 0.0 | 0.1 | V | I _O = 20 μA, V _I = V _{IL} |
| | | | 0.03 | 0.1 | V | I _O = 400 μA, V _I = V _{IL} |
| | | | 0.3 | 0.8 | V | I _O = 4 mA, V _I = V _{IL} |
| SWITCHING SPECIFICATIONS | | | | | | |
| For ADuM1100A | | | | | | |
| Minimum Pulsewidth ³ | PW | | | 40 | ns | C _L = 15 pF, CMOS Signal Levels |
| Maximum Data Rate ⁴ | | 25 | | | Mbps | C _L = 15 pF, CMOS Signal Levels |
| For ADuM1100B | | | | | | |
| Minimum Pulsewidth ³ | PW | | 6.7 | 10 | ns | C _L = 15 pF, CMOS Signal Levels |
| Maximum Data Rate ⁴ | | 100 | 150 | | Mbps | C _L = 15 pF, CMOS Signal Levels |
| For ADuM1100A and ADuM1100B | | | | | | |
| Propagation Delay Time to Logic Low Output ^{5, 6} (See TPC 3.) | t _{PHL} | | 10.5 | 18 | ns | C _L = 15 pF, CMOS Signal Levels |
| Propagation Delay Time to Logic High Output ^{5, 6} (See TPC 3.) | t _{PLH} | | 10.5 | 18 | ns | C _L = 15 pF, CMOS Signal Levels |
| Pulsewidth Distortion t _{PLH} - t _{PHL} ⁶ Change Versus Temperature ⁷ | PWD | | 0.5 | 2 | ns | C _L = 15 pF, CMOS Signal Levels |
| | | | 3 | | ps/°C | C _L = 15 pF, CMOS Signal Levels |
| Propagation Delay Skew (Equal Temperature) ^{6, 8} | t _{PSK1} | | | 8 | ns | C _L = 15 pF, CMOS Signal Levels |
| Propagation Delay Skew (Equal Temperature, Supplies) ^{6, 8} | t _{PSK2} | | | 6 | ns | C _L = 15 pF, CMOS Signal Levels |
| Output Rise Time (10%–90%) | t _R | | 3 | | ns | C _L = 15 pF, CMOS Signal Levels |
| Output Fall Time (90%–10%) | t _F | | 3 | | ns | C _L = 15 pF, CMOS Signal Levels |
| Common-Mode Transient Immunity at Logic High Output ⁹ | CM _H | 25 | 35 | | kV/μs | V _I = V _{DD1} , V _{CM} = 1000 V, Transient Magnitude = 800 V |
| Common-Mode Transient Immunity at Logic Low Output ⁹ | CM _L | 25 | 35 | | kV/μs | V _I = 0, V _{CM} = 1000 V, Transient Magnitude = 800 V |
| Input Dynamic Power Dissipation Capacitance ¹⁰ | C _{PD1} | | 35 | | pF | |
| Output Dynamic Power Dissipation Capacitance ¹⁰ | C _{PD2} | | 8 | | pF | |

ELECTRICAL SPECIFICATIONS, 3.3 V OPERATION¹ (3.0 V ≤ V_{DD1} ≤ 3.6 V, 3.0 V ≤ V_{DD2} ≤ 3.6 V. All Min/Max specifications apply over the entire recommended operation range unless otherwise noted. All typical specifications are at T_A = 25°C, V_{DD1} = V_{DD2} = 3.3 V.)

| Parameter | Symbol | Min | Typ | Max | Unit | Test Conditions |
|---|----------------------|------------------------|-------|------|-------|--|
| DC SPECIFICATIONS | | | | | | |
| Input Supply Current | I _{DD1(Q)} | | 0.1 | 0.3 | mA | V _I = 0 V or V _{DD1} |
| Output Supply Current | I _{DD2(Q)} | | 0.005 | 0.04 | mA | V _I = 0 V or V _{DD1} |
| Input Supply Current (25 Mbps) (See TPC 1.) | I _{DD1(25)} | | 2.0 | 2.8 | mA | 12.5 MHz Logic Signal Frequency |
| Output Supply Current ² (25 Mbps) (See TPC 2.) | I _{DD2(25)} | | 0.3 | 0.7 | mA | 12.5 MHz Logic Signal Frequency |
| Input Supply Current (50 Mbps) (See TPC 1.) | I _{DD1(50)} | | 4.0 | 6.0 | mA | 25 MHz Logic Signal Frequency, ADuM1100B Only |
| Output Supply Current ² (50 Mbps) (See TPC 2.) | I _{DD2(50)} | | 1.2 | 1.6 | mA | 25 MHz Logic Signal Frequency, ADuM1100B Only |
| Input Current | I _I | -10 | 0.01 | +10 | μA | 0 ≤ V _{IN} ≤ V _{DD1} |
| Logic High Output Voltage | V _{OH} | V _{DD2} - 0.1 | 3.3 | | V | I _O = -20 μA, V _I = V _{IH} |
| | | V _{DD2} - 0.5 | 3.0 | | V | I _O = -2.5 mA, V _I = V _{IH} |
| Logic Low Output Voltage | V _{OL} | | 0.0 | 0.1 | V | I _O = 20 μA, V _I = V _{IL} |
| | | | 0.04 | 0.1 | V | I _O = 400 μA, V _I = V _{IL} |
| | | | 0.3 | 0.4 | V | I _O = 2.5 mA, V _I = V _{IL} |
| SWITCHING SPECIFICATIONS | | | | | | |
| For ADuM1100A | | | | | | |
| Minimum Pulsewidth ³ | PW | | | 40 | ns | C _L = 15 pF, CMOS Signal Levels |
| Maximum Data Rate ⁴ | | 25 | | | Mbps | C _L = 15 pF, CMOS Signal Levels |
| For ADuM1100B | | | | | | |
| Minimum Pulsewidth ³ | PW | | 10 | 20 | ns | C _L = 15 pF, CMOS Signal Levels |
| Maximum Data Rate ⁴ | | 50 | 100 | | Mbps | C _L = 15 pF, CMOS Signal Levels |
| For ADuM1100A and ADuM1100B | | | | | | |
| Propagation Delay Time to Logic Low Output ^{5, 6} (See TPC 4.) | t _{PHL} | | 14.5 | 28 | ns | C _L = 15 pF, CMOS Signal Levels |
| Propagation Delay Time to Logic High Output ^{5, 6} (See TPC 4.) | t _{PLH} | | 15.0 | 28 | ns | C _L = 15 pF, CMOS Signal Levels |
| Pulsewidth Distortion t _{PLH} - t _{PHL} ⁶ Change Versus Temperature ⁷ | PWD | | 1.5 | 5 | ns | C _L = 15 pF, CMOS Signal Levels |
| | | | 10 | | ps/°C | C _L = 15 pF, CMOS Signal Levels |
| Propagation Delay Skew (Equal Temperature) ^{6, 8} | t _{PSK1} | | | 15 | ns | C _L = 15 pF, CMOS Signal Levels |
| Propagation Delay Skew (Equal Temperature, Supplies) ^{6, 8} | t _{PSK2} | | | 12 | ns | C _L = 15 pF, CMOS Signal Levels |
| Output Rise Time (10%–90%) | t _R | | 3 | | ns | C _L = 15 pF, CMOS Signal Levels |
| Output Fall Time (90%–10%) | t _F | | 3 | | ns | C _L = 15 pF, CMOS Signal Levels |
| Common-Mode Transient Immunity at Logic High Output ⁹ | CM _H | 15 | 20 | | kV/μs | V _I = V _{DD1} , V _{CM} = 1000 V, Transient Magnitude = 800 V |
| Common-Mode Transient Immunity at Logic Low Output ⁹ | CM _L | 15 | 20 | | kV/μs | V _I = 0, V _{CM} = 1000 V, Transient Magnitude = 800 V |
| Input Dynamic Power Dissipation Capacitance ¹⁰ | C _{PD1} | | 47 | | pF | |
| Output Dynamic Power Dissipation Capacitance ¹⁰ | C _{PD2} | | 14 | | pF | |

ADuM1100AR/ADuM1100BR—SPECIFICATIONS

NOTES

¹All voltages are relative to their respective ground.

²Output supply current values are with no output load present. The supply current drawn at a given signal frequency when an output load is present is given by:

$I_{DD2(L)} = I_{DD2} + V_{DD2} \times f \times C_L$, where I_{DD2} is the unloaded output supply current, f is the input signal frequency, and C_L is the output load capacitance.

³The minimum pulsewidth is the shortest pulsewidth at which the specified pulsewidth distortion is guaranteed.

⁴The maximum data rate is the fastest data rate at which the specified pulsewidth distortion is guaranteed.

⁵ t_{PHL} is measured from the 50% level of the falling edge of the V_I signal to the 50% level of the falling edge of the V_O signal. t_{PLH} is measured from the 50% level of the rising edge of the V_I signal to the 50% level of the rising edge of the V_O signal.

⁶Since the input thresholds of the ADuM1100 are at voltages other than the 50% level of typical input signals, the measured propagation delay and pulsewidth distortion may be affected by slow input rise/fall times. See application note “Propagation Delay-Related Parameters” and Figures 3–7 for information on the impact of given input rise/fall times on these parameters.

⁷Pulsewidth distortion change versus temperature is the absolute value of the change in pulsewidth distortion for a 1 °C change in operating temperature.

⁸ t_{PSK1} is the magnitude of the worst-case difference in t_{PHL} and/or t_{PLH} that will be measured between units at the same operating temperature and output load within the recommended operating conditions. t_{PSK2} is the magnitude of the worst-case difference in t_{PHL} and/or t_{PLH} that will be measured between units at the same operating temperature, supply voltages, and output load within the recommended operating conditions.

⁹ CM_H is the maximum common-mode voltage slew rate that can be sustained while maintaining $V_O > 0.8 V_{DD2}$. CM_L is the maximum common-mode voltage slew rate that can be sustained while maintaining $V_O < 0.8 V$. The common-mode voltage slew rates apply to both rising and falling edges. The transient magnitude is the range over which the common-mode is slewed.

¹⁰The Dynamic Power Dissipation Capacitance is given by:

$C_{PDi} = (I_{DDi(100)} - I_{DDi(Q)}) / (V_{DDi} \times f)$, where $i = 1$ or 2 and f is the input signal frequency.

The supply current consumptions at a given frequency and output load are calculated as follows:

$I_{DD1} = C_{PD1} \times V_{DD1} \times f + I_{DD1(Q)}$; $I_{DD2(L)} = (C_{PD2} + C_L) \times V_{DD2} \times f + I_{DD2(Q)}$, where C_L is the output load capacitance.

Specifications subject to change without notice.

PACKAGE CHARACTERISTICS

| Parameter | Symbol | Min | Typ | Max | Unit | Test Conditions |
|---|----------------|-----|------------------|-----|----------|--|
| Resistance (Input-Output) ¹ | R_{I-O} | | 10 ¹² | | Ω | f = 1 MHz Thermocouple Located at Center Underside of Package |
| Capacitance (Input-Output) ¹ | C_{I-O} | | 1 | | pF | |
| Input Capacitance ² | C_I | | 4.0 | | pF | |
| Input IC Junction-to-Case Thermal Resistance | θ_{JCI} | | 46 | | °C/W | |
| Output IC Junction-to-Case Thermal Resistance | θ_{JCO} | | 41 | | °C/W | |
| Package Power Dissipation | P_{PD} | | | 240 | mW | |

NOTES

¹Device considered a two-terminal device: Pins 1, 2, 3, and 4 shorted together and Pins 5, 6, 7, and 8 shorted together.

²Input capacitance is measured at Pin 2 (V_I).

REGULATORY INFORMATION

The ADuM1100AR/ADuM1100BR has been approved by the following organizations:

| UL | CSA | VDE |
|--|--|--|
| Recognized under 1577 Component Recognition Program ¹ | Approved under CSA Component Acceptance Notice #5A, C22.2 No. 1-98, C22.2 No. 14-95, and C22.2 No. 950-95 File 205078 0 000. | Approved According to VDE 0884 ² File 24719-4880-0001/32 KJY F33/PZ |
| File E214100 | | |

NOTES

¹In accordance with UL 1577, each ADuM1100 is proof tested by applying an insulation test voltage ≥ 3000 Vrms for 1 second (leakage detection current limit, $I_{I-O} \leq 5 \mu A$).

²In accordance with VDE 0884, each ADuM1100 is proof tested by applying an insulation test voltage $\geq 1050 V_{PEAK}$ for 1 second (partial discharge detection limit ≤ 5 pC).

INSULATION AND SAFETY-RELATED SPECIFICATIONS

| Parameter | Symbol | Value | Unit | Conditions |
|--|--------|-----------|------|---|
| Minimum External Air Gap (Clearance) | L(I01) | 4.90 min | mm | Measured from input terminals to output terminals, shortest distance through air. |
| Minimum External Tracking (Creepage) | L(I02) | 4.01 min | mm | Measured from input terminals to output terminals, shortest distance path along body. |
| Minimum Internal Gap (Internal Clearance) | | 0.016 min | mm | Insulation distance through insulation. |
| Tracking Resistance (Comparative Tracking Index) | CTI | >175 | V | DIN IEC 112/VDE 0303 Part 1. |
| Isolation Group | | IIIa | | Material Group (DIN VDE 0110,1/89, Table 1). |

VDE 0884 INSULATION CHARACTERISTICS

| Description | Symbol | Characteristic | Unit |
|--|-----------------|-----------------------|------------|
| Installation Classification per DIN VDE 0110 For Rated Mains Voltage ≤150 V rms For Rated Mains Voltage ≤300 V rms For Rated Mains Voltage ≤400 V rms | | I-IV I-III I-II | |
| Climatic Classification | | 40/100/21 | |
| Pollution Degree (DIN VDE 0110, Table I) | | 2 | |
| Maximum Working Insulation Voltage | V_{IORM} | 560 | V_{PEAK} |
| Input to Output Test Voltage, Method B $V_{IORM} \times 1.875 = V_{PR}$, 100% Production Test, $t_M = 1$ sec, Partial Discharge < 5 pC | V_{PR} | 1050 | V_{PEAK} |
| Input to Output Test Voltage, Method A $V_{IORM} \times 1.5 = V_{PR}$, Type and Sample Test, $t_M = 60$ sec, Partial Discharge < 5 pC | V_{PR} | 840 | V_{PEAK} |
| Highest Allowable Overvoltage (Transient Overvoltage, $t_{TR} = 10$ sec) | V_{TR} | 4000 | V_{PEAK} |
| Safety-Limiting Values (Maximum Value Allowed in the Event of a Failure, Also See Thermal Derating Curve, Figure 1) | | | |
| Case Temperature | T_S | 150 | °C |
| Input Current | $I_{S, INPUT}$ | 160 | mA |
| Output Current | $I_{S, OUTPUT}$ | 170 | mA |
| Insulation Resistance at T_S , $V_{IO} = 500$ V | R_S | >10 ⁹ | Ω |

NOTE

This isolator is suitable for “safe electrical isolation” only within the safety limit data. Maintenance of the safety data shall be ensured by means of protective circuits.
♦ marking on package denotes VDE 0884 approval for 560 V_{PEAK} working voltage.

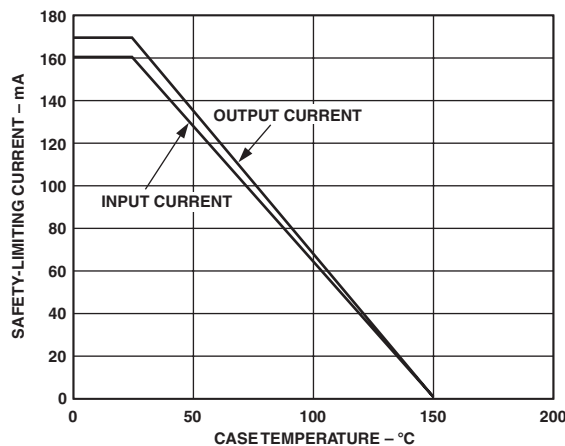

Figure 1. Thermal Derating Curve, Dependence of Safety Limiting Values with Case Temperature per VDE 0884

ADuM1100AR/ADuM1100BR

RECOMMENDED OPERATING CONDITIONS

| Parameter | Symbol | Min | Max | Unit |
|---|--------------------|-----|-----------|------|
| Operating Temperature | T_A | -40 | +100 | °C |
| Supply Voltages ^{1, 2} | V_{DD1}, V_{DD2} | 3.0 | 5.5 | V |
| Logic High Input Voltages, 5 V Operation ^{1, 3} (See TPCs 5 and 6) | V_{IH} | 2.0 | V_{DD1} | V |
| Logic Low Input Voltages, 5 V Operation ^{1, 3} (See TPCs 5 and 6) | V_{IL} | 0.0 | 0.8 | V |
| Logic High Input Voltages, 3.3 V Operation ^{1, 3} (See TPCs 5 and 6) | V_{IH} | 1.5 | V_{DD1} | V |
| Logic Low Input Voltage, 3.3 V Operation ^{1, 3} (See TPCs 5 and 6) | V_{IL} | 0.0 | 0.5 | V |
| Input Signal Rise and Fall Times | | | 1.0 | ms |

NOTES

¹All voltages are relative to their respective ground.

² V_{DD1} and V_{DD2} must be kept within 1 V of each other ($|[V_{DD1} - GND_1] - [V_{DD2} - GND_2]| < 1$ V).

³Input switching thresholds have 300 mV of hysteresis.

See application note “Method of Operation, DC Correctness, and Magnetic Field Immunity” and Figure 9 for information on immunity to external magnetic fields.

ABSOLUTE MAXIMUM RATINGS¹

| Parameter | Symbol | Min | Max | Unit |
|--|---|------|-----------------|------|
| Storage Temperature | T_S | -55 | +125 | °C |
| Ambient Operating Temperature | T_A | -40 | +105 | °C |
| Supply Voltages ² | V_{DD1}, V_{DD2} | -0.5 | +6.5 | V |
| Input Voltage ² | V_I | -0.5 | $V_{DD1} + 0.5$ | V |
| Output Voltage ² | V_O | -0.5 | $V_{DD2} + 0.5$ | V |
| Average Current, Per Pin | | -25 | +25 | mA |
| ESD (Human Body Model) | | -2.0 | +2.0 | kV |
| Lead Solder Temperature (Hand Soldering) | Heating at Lead Tip 275°C ±10°C for 20 Seconds | | | |
| Solder Reflow Temperature Profile | JEDEC Standard 20A | | | |

NOTES

¹Stresses above those listed under Absolute Maximum Ratings may cause permanent damage to the device. This is a stress rating only. Functional operation of the device at these or any other conditions above those listed in the operational sections of this specification is not implied. Exposure to absolute maximum rating conditions for extended periods may affect device reliability. Absolute maximum ratings apply individually only, not in combination. Ambient temperature = 25°C unless otherwise noted.

²All voltages are relative to their respective ground.

ADuM1100AR/ADuM1100BR

Table I. Truth Table (Positive Logic)

| V _I , Input | V _{DD1} State | V _{DD2} State | V _O , Output | Note |
|---------------------------|---------------------------|---------------------------|----------------------------|--|
| H | Powered | Powered | H | |
| L | Powered | Powered | L | |
| X | Unpowered | Powered | H | V _O returns to V _I state within 1 μs of power restoration. |
| X | Powered | Unpowered | X | V _O returns to V _I state within 1 μs of power restoration. |

ORDERING GUIDE

| Model | Temperature Range | Max Data Rate (Mbps) | Min Pulse-Width (ns) | Package Description | Package Option |
|----------------|-------------------|----------------------|----------------------|----------------------|----------------|
| ADuM1100AR | -40°C to +100°C | 25 | 40 | 8-Lead SOIC | SO-8 |
| ADuM1100BR | -40°C to +100°C | 100 | 10 | 8-Lead SOIC | SO-8 |
| ADuM1100AR-RL7 | -40°C to +100°C | 25 | 40 | 13" Reel 8-Lead SOIC | SO-8 |
| ADuM1100BR-RL7 | -40°C to +100°C | 100 | 10 | 13" Reel 8-Lead SOIC | SO-8 |

PIN CONFIGURATION

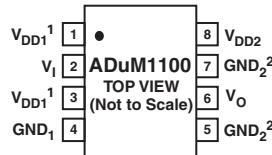

NOTES

- ¹ PIN 1 AND PIN 3 ARE INTERNALLY CONNECTED. EITHER OR BOTH MAY BE USED FOR V_{DD1}.
- ² PIN 5 AND PIN 7 ARE INTERNALLY CONNECTED. EITHER OR BOTH MAY BE USED FOR GND₂.

Note: Package branding is as follows

ADuM1100AR, ADuM1100AR-RL7

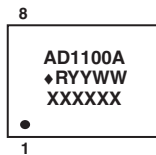

ADuM1100BR, ADuM1100BR-RL7

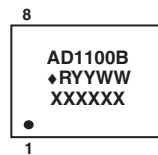

where:

- ♦ = VDE 0884 mark
- R = Package Designator (R denotes SOIC)
- YYWW = Date Code
- XXXXXX = Lot Code

CAUTION

ESD (electrostatic discharge) sensitive device. Electrostatic charges as high as 4000 V readily accumulate on the human body and test equipment and can discharge without detection. Although the ADuM1100AR/ADuM1100BR features proprietary ESD protection circuitry, permanent damage may occur on devices subjected to high-energy electrostatic discharges. Therefore, proper ESD precautions are recommended to avoid performance degradation or loss of functionality.



ADuM1100AR/ADuM1100BR—Typical Performance Characteristics

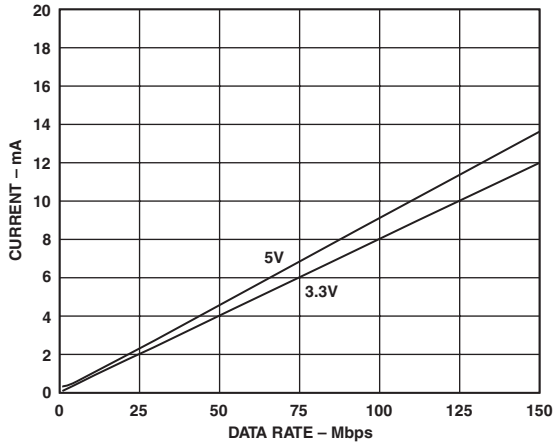

TPC 1. Typical Input Supply Current vs. Logic Signal Frequency for 5 V and 3.3 V Operation

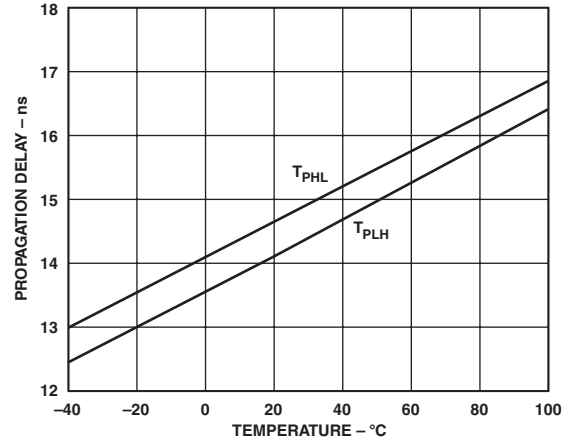

TPC 4. Typical Propagation Delay vs. Temperature, 3.3 V Operation

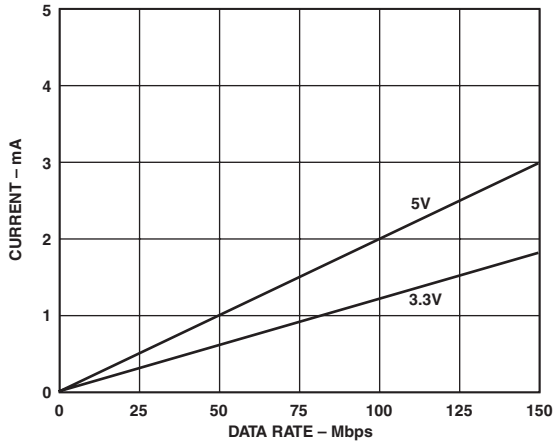

TPC 2. Typical Output Supply Current vs. Logic Signal Frequency for 5 V and 3.3 V Operation

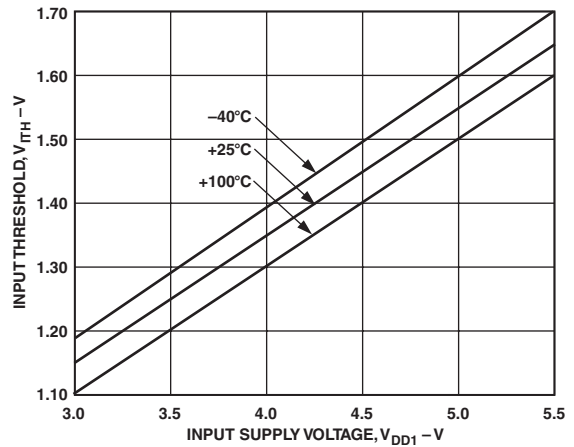

TPC 5. Typical Input Voltage Switching Threshold, Low-to-High Transition

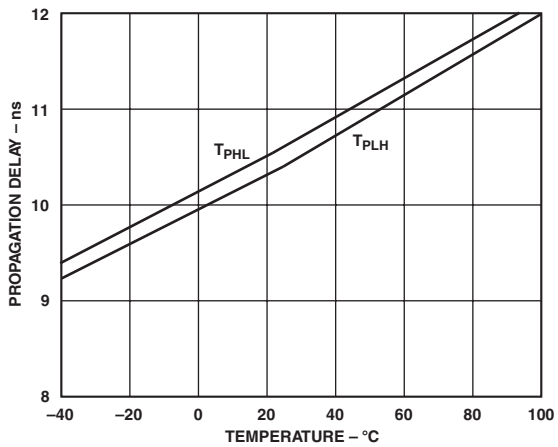

TPC 3. Typical Propagation Delay vs. Temperature, 5 V Operation

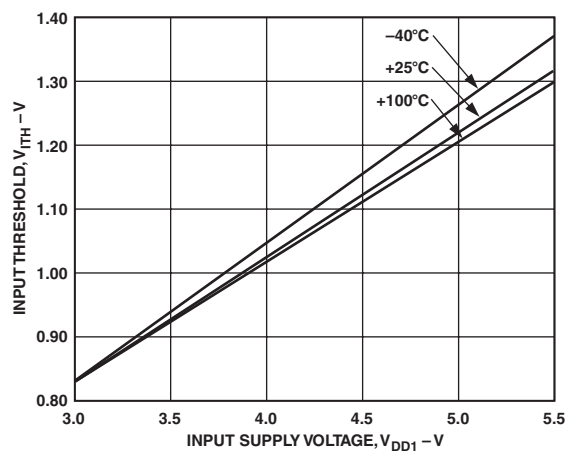

TPC 6. Typical Input Voltage Switching Threshold, High-to-Low Transition

APPLICATION INFORMATION

PC Board Layout

The ADuM1100 digital isolator requires no external interface circuitry for the logic interfaces. A bypass capacitor is recommended at the input and output supply pins. The input bypass capacitor may most conveniently be connected between Pins 3 and 4 (Figure 2). Alternatively, the bypass capacitor may be located between Pins 1 and 4. The output bypass capacitor may be connected between Pins 7 and 8 or Pins 5 and 8. The capacitor value should be between 0.01 μF and 0.1 μF . The total lead length between both ends of the capacitor and the power supply pins should not exceed 20 mm.

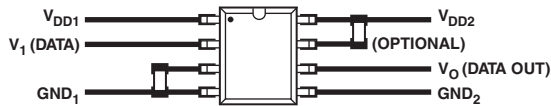

Figure 2. Recommended Printed Circuit Board Layout

Propagation Delay-Related Parameters

Propagation delay time is a parameter that describes the length of time it takes for a logic signal to propagate through a component. Propagation delay time to logic low output and propagation delay time to logic high output refer to the duration between an input signal transition and the respective output signal transition (Figure 3).

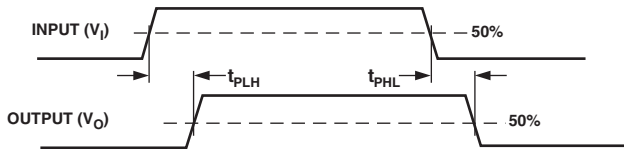

Figure 3. Propagation Delay Parameters

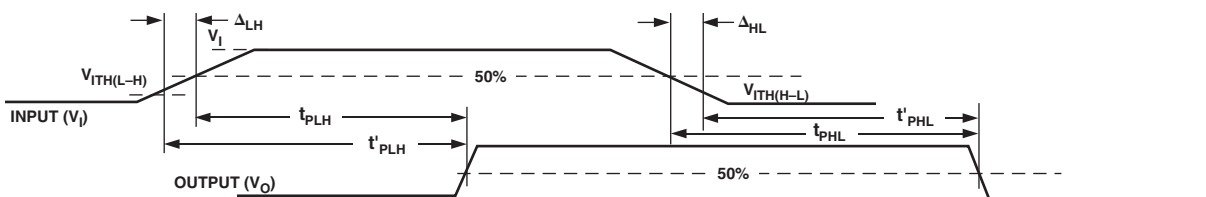

Figure 4. Impact of Input Rise/Fall Time on Propagation Delay

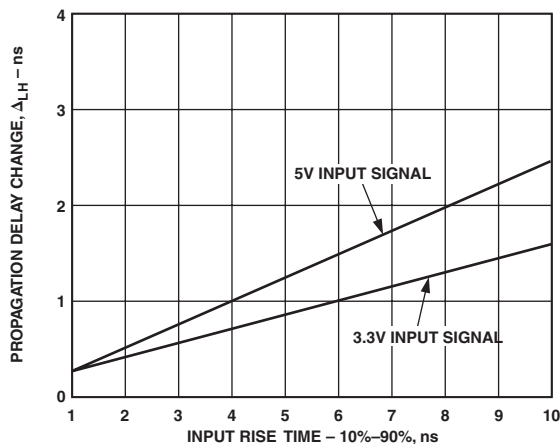

Figure 5. Typical Propagation Delay Change Due to Input Rise Time Variation (for $V_{DD1} = 3.3 \text{ V}$ and 5 V)

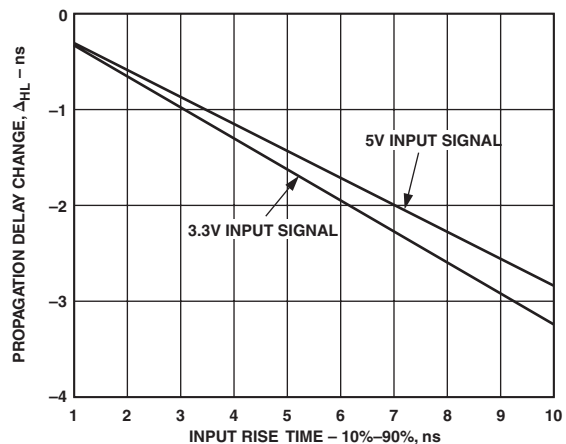

Figure 6. Typical Propagation Delay Change Due to Input Fall Time Variation (for $V_{DD1} = 3.3 \text{ V}$ and 5 V)

ADuM1100AR/ADuM1100BR

The impact of slower input edge rates can also affect the measured pulsewidth distortion as based on the input 50% level. This impact may either increase or decrease the apparent pulsewidth distortion depending on the relative magnitudes of t_{PHL} , t_{PLH} , and PWD. The case of interest here is the condition that leads to the largest increase in pulsewidth distortion. The change in this case is given by:

$$\Delta_{PWD} = PWD' - PWD = \Delta_{LH} - \Delta_{HL} = (t/0.8 V_1)(V - V_{ITH(L-H)} - V_{ITH(H-L)}), \text{ (for } t = t_r = t_f)$$

where:

$$PWD = |t_{PLH} - t_{PHL}|$$

$$PWD' = |t'_{PLH} - t'_{PHL}|$$

This adjustment in pulsewidth distortion is plotted as a function of input rise/fall time in Figure 7.

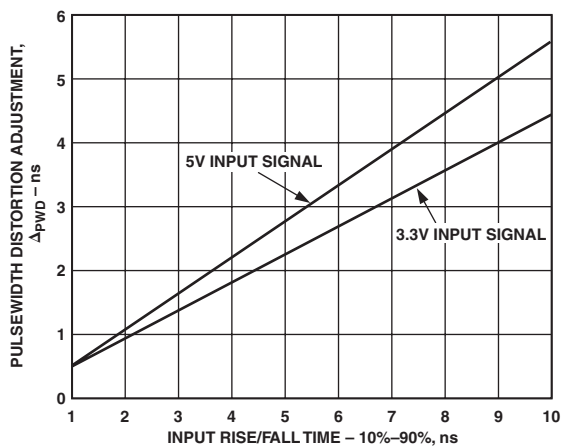

Figure 7. Typical Pulsewidth Distortion Adjustment Due to Input Rise/Fall Time Variation (at $V_{DD1} = 3.3 \text{ V}$ and 5 V)

Method of Operation, DC Correctness, and Magnetic Field Immunity

Referring to the functional block diagram, the two coils act as a pulse transformer. Positive and negative logic transitions at the isolator input cause narrow (2 ns) pulses to be sent via the transformer to the decoder. The decoder is bistable and therefore either set or reset by the pulses indicating input logic transitions. In the absence of logic transitions at the input for more than 2 μs , a periodic “update” pulse of the appropriate polarity is sent to ensure “dc correctness” at the output. If the decoder receives none of these “update” pulses for more than about 5 μs , the input side is assumed to be unpowered or nonfunctional, in which case the isolator output is forced to a logic high state by the watchdog timer circuit.

The limitation on the ADuM1100’s magnetic field immunity is set by the condition in which induced voltage in the transformer’s “receiving” coil is sufficiently large to either falsely set or reset the decoder. The analysis below defines the conditions under which this may occur. The ADuM1100’s 3.3 V operating condition is examined as it represents the most susceptible mode of operation.

The pulses at the transformer output are greater than 1.0 V in amplitude. The decoder has sensing thresholds at about 0.5 V, therefore establishing a 0.5 V margin in which induced voltages can be tolerated. The induced voltage induced across the “receiving” coil is given by:

$$V = (-d\beta/dt)\Sigma\pi r_n^2; n = 1, 2, \dots, N$$

where:

β = magnetic flux density (Gauss).

N = number of turns in receiving coil.

r_n = radius of nth turn in receiving coil (cm).

Given the geometry of the receiving coil in the ADuM1100, and an imposed requirement that the induced voltage be at most 50% of the 0.5 V margin at the decoder, a maximum allowable magnetic field is calculated as shown in Figure 8. A 50% margin is maintained to accommodate the possibility of input voltage transients occurring in conjunction with the external magnetic field disturbance.

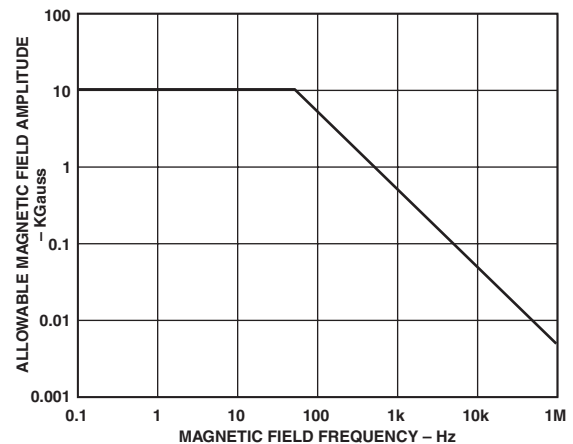

Figure 8. Maximum Allowable External Magnetic Field

For example, at a magnetic field frequency of 1 MHz, the maximum allowable magnetic field of 0.5 K Gauss induces a voltage of 0.25 V at the receiving coil. This is about 50% of the sensing threshold and will not cause a faulty output transition. Similarly, if such an event were to occur during a transmitted pulse (and was of the worst-case polarity), it would reduce the received pulse from > 1.0 V to 0.75 V—still well above the 0.5 V sensing threshold of the Decoder.

Note that at combinations of strong magnetic field and high frequency, any loops formed by printed circuit board traces could induce sufficiently large error voltages to trigger the thresholds of succeeding circuitry. Care should be taken in the layout of such traces to avoid this possibility.

*i*Coupler in Field Bus Networks

The emergence of field bus communication networks such as PROFIBUS or DeviceNet™ has enabled higher levels of control in industrial automation systems than previously possible. These networks, interconnecting sensors, actuators, controllers, and various other devices, typically recommend the use of galvanic isolation at each interface location (Figure 9). The use of galvanic isolation in the network increases data integrity and provides protection from power faults and ground loop effects.

The ADuM1100, using *i*Coupler technology, provides a superior isolation solution for field bus networks than alternatives such as optocouplers. The ADuM1100AR provides superior propagation delay and pulsewidth distortion performance, a higher level of common-mode transient immunity, and a substantial reduction in power consumption relative to optocoupler devices. The ADuM1100BR offers all of the same advantages and supports a four-fold increase in data rate to 100 Mbps.

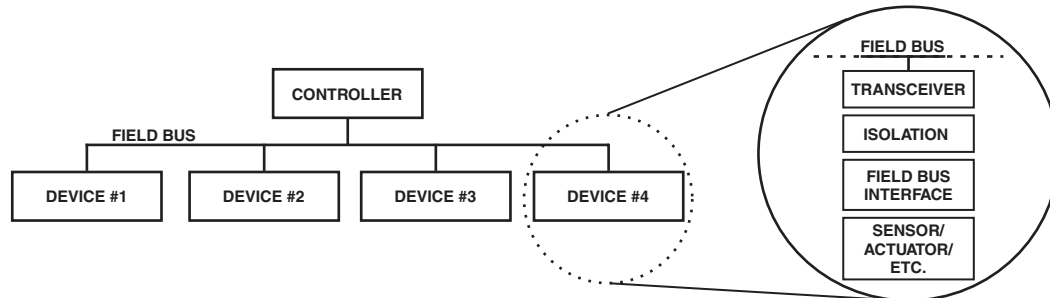

Figure 9. Representative Field Bus Configuration

ADuM1100AR/ADuM1100BR

OUTLINE DIMENSIONS

Dimensions shown in inches and (mm).

8-Lead SOIC (R-8)

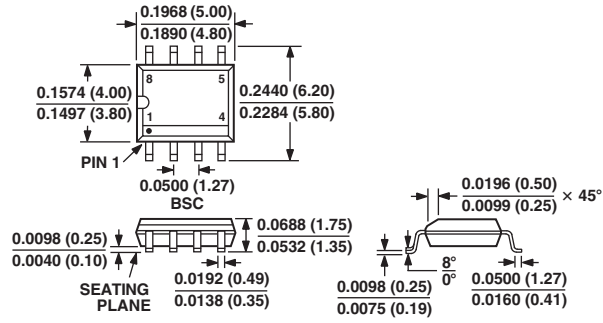

C02462-1-7/01(0)

PRINTED IN U.S.A.