

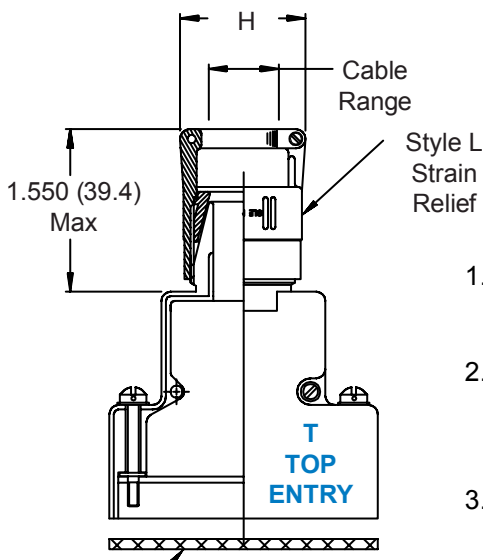

550-001 EMI/RFI D-Subminiature Split Backshell for Individual or Overall Shielding with Strain Relief

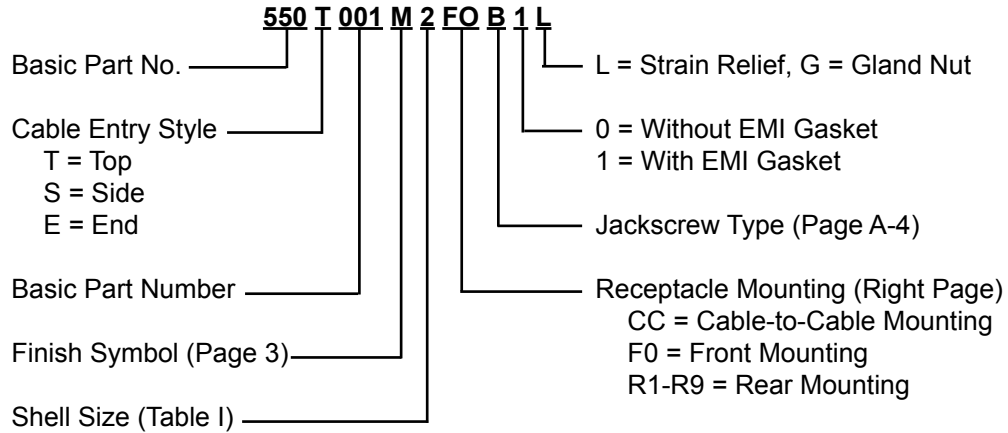

EMI Gasket (Optional)

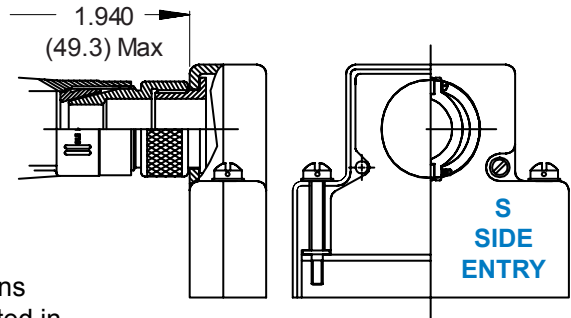

1. Metric dimensions (mm) are indicated in parentheses.
2. **DO NOT USE CONNECTORS WITH FLOAT MOUNTINGS.**
3. Overall shield. Thickness range: 0 to .062 (1.6)

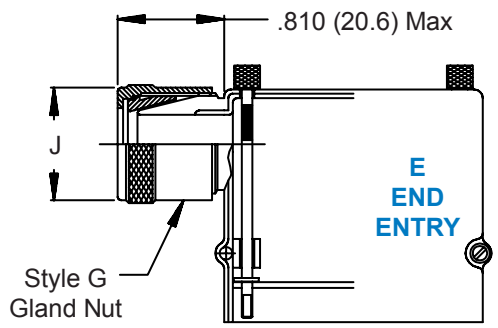

TABLE I: CABLE ENTRY & ENTRY STYLE

Shell Size	Com'l Shell Size Ref	H Max	J Max	Entry Styles S & T Cable Range		Entry Style E Cable Range	
				Min	Max	Min	Max
				1	E/09	1.046 (26.6)	.843 (21.4)
2	A/15	1.046 (26.6)	.843 (21.4)	.250 (6.4)	.375 (9.5)	.250 (6.4)	.375 (9.5)
3	B/25	1.156 (29.4)	.968 (24.6)	.312 (7.9)	.475 (12.1)	.312 (7.9)	.475 (12.1)
4	C/37	1.156 (29.4)	.968 (24.6)	.312 (7.9)	.475 (12.1)	.312 (7.9)	.475 (12.1)
5	D/50	1.218 (30.9)	1.109 (28.2)	.437 (11.1)	.575 (14.6)	.437 (11.1)	.575 (14.6)
6*	F/104	1.594 (40.5)	1.468 (37.3)	.812 (20.6)	1.000 (25.4)	n/a	n/a

* Shell Size 6 Available in Top Entry Only.

D-Subminiature Split Backshells Standard Dimensions



COMMON CONNECTOR/SHELL INTERFACE & BACKSHELL DIMENSIONS

Com'l Shell Size	Shell Ref	A		B		C Ref.		D		P	R Ref		
		Max	(mm)	Max	(mm)		(mm)	$\pm .005$	(mm)				
1	E/09	1.393	(35.4)	.624	(15.8)	.312	(7.9)	.984	(25.0)	.730	(18.5)	.719	(18.3)
2	A/15	1.706	(43.3)	.624	(15.8)	.312	(7.9)	1.312	(33.3)	1.050	(26.7)	.719	(18.3)
3	B/25	2.265	(57.5)	.624	(15.8)	.312	(7.9)	1.852	(47.0)	1.594	(40.5)	.938	(23.8)
4	C/37	2.900	(73.7)	.624	(15.8)	.312	(7.9)	2.500	(63.5)	2.240	(56.9)	.938	(23.8)
5	D/50	2.800	(71.1)	.750	(19.1)	.375	(9.5)	2.406	(61.1)	2.140	(54.4)	.938	(23.8)
6	F/104	2.900	(73.7)	.844	(21.4)	.422	(10.7)	2.500	(63.5)	2.240	(56.9)	1.094	(27.8)

CABLE MOUNTING AND BACKSHELL DIMENSIONS

Dash No.	Panel Thickness	E	F $\pm .031$ (0.79)			G $\pm .031$ (0.79)	
			Sizes 1 & 2	Sizes 3 - 5	Size 6	Sizes 1 & 2	Sizes 3 - 5
CC	n/a	.174 (4.4)	1.451 (36.9)	1.671 (42.4)	1.820 (46.2)	1.583 (40.2)	1.831 (46.5)
F0	n/a	.343 (8.7)	1.625 (41.3)	1.844 (46.8)	2.000 (50.8)	1.750 (44.5)	2.000 (50.8)
R1	.031 (.8)	.247 (6.3)	1.525 (38.7)	1.745 (44.3)	1.890 (48.0)	1.656 (42.1)	1.904 (48.4)
R2	.047 (1.2)	.231 (5.9)	1.509 (38.3)	1.728 (43.9)	1.875 (47.6)	1.640 (41.7)	1.888 (48.0)
R3	.062 (1.6)	.216 (5.5)	1.500 (38.1)	1.720 (43.7)	1.860 (47.2)	1.625 (41.3)	1.873 (47.6)
R4	.093 (2.4)	.185 (4.7)	1.470 (37.3)	1.690 (42.9)	1.829 (46.5)	1.594 (40.5)	1.842 (46.8)
R5	.104 (2.6)	.174 (4.4)	1.451 (36.9)	1.671 (42.4)	1.820 (46.2)	1.583 (40.2)	1.831 (46.5)
R6	.125 (3.2)	.153 (3.9)	1.430 (36.3)	1.650 (41.9)	1.798 (45.7)	1.563 (39.7)	1.811 (46.0)
R7	.156 (4.0)	.125 (3.2)	1.400 (35.6)	1.620 (41.1)	1.767 (44.9)	1.531 (38.9)	1.781 (45.2)
R8	.135 (3.4)	.140 (3.6)	1.417 (36.0)	1.637 (41.6)	1.805 (45.8)	1.550 (39.4)	1.798 (45.7)
R9	.188 (4.8)	.094 (2.4)	1.368 (34.7)	1.590 (40.4)	1.740 (44.2)	1.500 (38.1)	1.750 (44.5)

Metric dimensions (mm) are indicated in parentheses.

Mouser Electronics

Authorized Distributor

Click to View Pricing, Inventory, Delivery & Lifecycle Information:

Glenair:

[550T001M5F0D1L](#) [550E001NF1R3J1G](#) [550E001NF3R3J0L](#) [550T001M1R3K1L](#) [550S001NF4R5K0L](#)
[550E001NF1F0J1L](#) [550T001M1R4K0L](#) [550S001M4F0K0L](#) [550T001M5R3E1L](#) [550T001NF4F0K0L](#)
[550T001NF1R1E0G](#) [550E001NF3R5J0L](#) [550T001M3R7E0L](#) [550T001M5R7K0L](#) [550T001M6R3H0L](#)
[550T001M2R3H0L](#) [550T001NF1R3E1L](#) [550T001M2F0K0L](#) [550T001M1R3H0L](#) [550E001M3R3J1L](#)
[550T001NF4R5K0L](#) [550T001NF1R7L0G](#) [550T001M3R3K1L](#) [550T001NF5R4M0L](#) [550E001M2R3J1L](#)
[550T001M1R6K0L](#) [550T001M1R4M1L](#) [550S001M2R1K1L](#) [550T001M1R7E0L](#) [550T001M4R7E0L](#)
[550T001NF3F0B1L](#) [550T001M1R9E0L](#) [550E001M1R3J0G](#) [550T001M1F0K0L](#) [550T001M1R4K1G](#)
[550T001M3R3E0L](#) [550T001M5R4K1G](#) [550T001NF2F0E0L](#) [550T001NF2R5E0L](#) [550T001M1F0H1L](#)
[550T001M4R3E0L](#) [550E001A3R3J0L](#) [550S001M3R1K1L](#) [550T001M3R3D0L](#) [550E001NF1R5J0L](#)
[550T001M3R3E1G](#) [550T001M5R7E0L](#) [550E001NF1R6J1L](#) [550T001M2R9L0L](#) [550T001NF1F0B0L](#)
[550E001A2R3H1L](#) [550S001M5F0E0L](#) [550T001NF5F0E0L](#)