

20-50 GHz GaAs Surface Mount LO Driver Amplifier

AMM-6702SM

1. Device Overview

1.1 General Description

The AMM-6702SM is a surface-mount LO driver amplifier that is designed to provide sufficient LO drive for an H or S diode mixer such as the MM1-1850HSM or MM1-1850SSM across temperature with input power from 0-10 dBm. This ferritic package offers improved resilience to radiative feedback and oscillatory behavior over the bare-die package option, providing the customer with a compact, high gain, wideband LO driver amplifier.

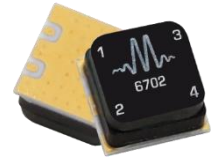

Surface Mount KFN

1.2 Features

- High gain
- Broadband performance
- +19 dBm output power
- Compact package
- Radar and satellite communications
- 5G transceivers
- Optimal LO driver amp for Marki S-diode mixers

1.3 Applications

- Mobile test and measurement equipment

1.4 Functional Block Diagram

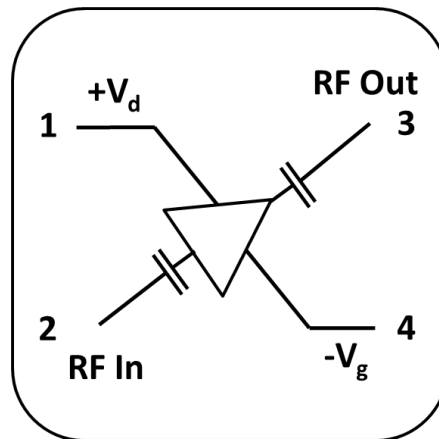

1.5 Part Ordering Options¹

Part Number	Description	Package	Green Status	Product Lifecycle	Export Classification
AMM-6702SM	4x4 mm Surface Mount	KFN	RoHS	Active	3A001.b.2.d
EVAL-AMM-6702SM	Connectorized Evaluation Fixture	EVAL	RoHS	Active	EAR99

¹ Refer to our [website](#) for a list of definitions for terminology presented in this table.

Table of Contents

1. Device Overview	1	3.4 Sequencing Requirements	5
1.1 General Description.....	1	3.5 Electrical Specifications	6
1.2 Features	1	3.6 Typical Performance Plots	7
1.3 Applications	1	3.7 Conversion Loss of Marki Surface Mount Mixers Using AMM-6702SM as LO Driver	9
1.4 Functional Block Diagram	1	4. Application Information	10
1.5 Part Ordering Options.....	1	4.1 Preventing oscillatory behavior	10
2. Port Configurations and Functions	3	4.2 Bypass Capacitance	10
2.1 Port Diagram	3	4.3 Example Application Circuits	11
2.2 Port Functions	3	5. Mechanical Data	12
3. Specifications	4	5.1 SMT Package Outline Drawing	12
3.1 Absolute Maximum Ratings.....	4	5.2 AMM-6702SM Landing Pattern.....	12
3.2 Package Information	4	5.3 EVAL Package Outline Drawing	13
3.3 Recommended Operating Conditions .	5		

Revision History

Revision Code	Revision Date	Comment
-	October 2019	Datasheet Initial Release
A	October 2019	Updated Performance Plots
B	November 2019	Mixer Performance Plots & Application Circuits
C	November 2019	Production fixture minimum gain spec modified
D	January 2020	Gain and Power Output Performance Plots Updated
E	February 2020	Added content to section 4.1
F	June 2020	Updated Maximum Ratings
G	August 2020	Updated Landing Pattern
H	November 2020	Updated Thermal Specs and IP3 specs, added link to landing pattern
I	November 2020	Updated Min Frequency Spec

2. Port Configurations and Functions

2.1 Port Diagram

A top-down (left) and bottom-up (right) view of the AMM-6702SM's KFN package outline drawing is shown below. The pin functions are detailed in section 2.2 of this datasheet.

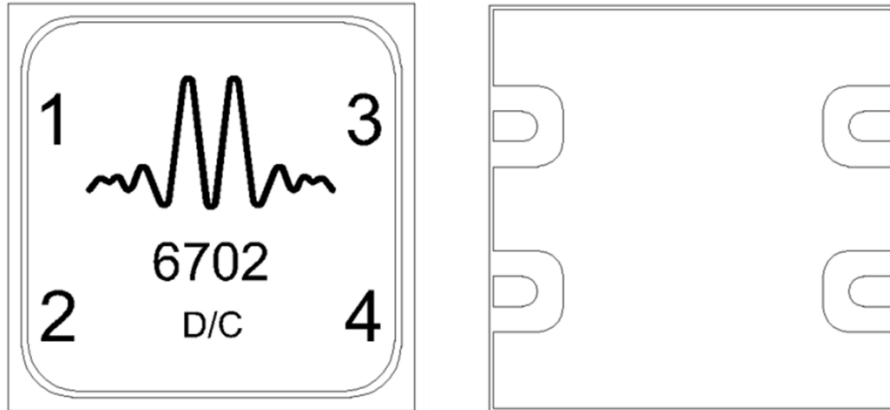

2.2 Port Functions

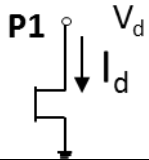
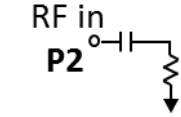
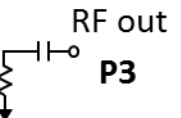
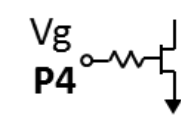
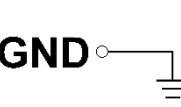
Port	Function	Description	Equivalent Circuit for Package
Pin 1	Positive DC Supply V_d	Pin 1 provides +2V to +4V DC voltage and drain current to the amplifier. Negative voltage must be supplied to Pin 4 before turning on the positive supply voltage.	
Pin 2	RF Input	Pin 2 is the RF input of the amplifier. It is internally DC blocked.	
Pin 3	RF Output	Pin 3 is the RF output of the amplifier. It is internally DC blocked.	
Pin 4	Negative DC Supply V_g	Pin 4 provides -0.4V to -0.6V of DC voltage. This must be turned on before turning on the positive supply voltage to Pin 1.	
GND	Ground	Bottom side must be connected to a DC/RF ground potential with high thermal and electrical conductivity.	

3. Specifications

3.1 Absolute Maximum Ratings

The Absolute Maximum Ratings indicate limits beyond which damage may occur to the device. If these limits are exceeded, the device may be inoperable or have a reduced lifetime.

Parameter	Maximum Rating	Units
Positive Bias Voltage (Pin 1)	4.5	V
Positive Bias Current (Pin 1) ²	400	mA
Negative Bias Voltage (Pin 4)	-2	V
Negative Bias Current (Pin 4)	10	μA
RF Input Power	+22	dBm
Continuous Power Dissipation (P _{DISS})	824	mW
Operating Temperature	-40 to +85	°C
Storage Temperature	-65 to +150	°C
θ_{JC}	93	°C/W
Max Junction Temperature for MTTF > 1E6 Hours	175	°C

3.2 Package Information

Parameter	Details	Rating
ESD	Human Body Model (HBM), per MIL-STD-750, Method 1020	Class 0
Weight	EVAL Package	24.4g

² Maximum current draw is 400 mA when not limited by continuous power dissipation rating

3.3 Recommended Operating Conditions

The Recommended Operating Conditions indicate the limits, inside which the device should be operated, to guarantee the performance given in Electrical Specifications (3.5). Operating outside these limits may not necessarily cause damage to the device, but the performance may degrade outside the limits of the Electrical Specifications. For limits, above which damage may occur, see Absolute Maximum Ratings (3.1).

	Min	Nominal	Max	Units
T _A , Ambient Temperature	-55	+25	+85	°C
Positive DC Voltage	+2	+3	+4	V
Positive DC Current	100	180	350	mA
Negative DC Voltage	-0.4	-0.5	-0.6	V

3.4 Sequencing Requirements

Turn-on Procedure:

- 1) Apply $<-0.4\text{V}$ to V_g (Pin 4)
- 2) Apply V_d (Pin 1)

Turn-off Procedure:

- 1) Turn off V_d (Pin 1)
- 2) Turn off V_g (Pin 4)

3.5 Electrical Specifications

The electrical specifications apply at $T_A=+25^{\circ}\text{C}$ in a 50Ω system.

Min and Max limits apply only to our connectorized units and are guaranteed at $T_A=+25^{\circ}\text{C}$.

Parameter	Test Conditions	Min ³	Typical	Max	Units
Frequency Range		21		50	GHz
Saturated Output Power	3V/-0.5V bias, +5 dBm Input Power		19		dBm
	3.5V/-0.5V bias, +5 dBm Input Power	17	20		
	4V/-0.5V bias, +5 dBm Input Power		20		
Small Signal Gain	3V/-0.5V bias, -25 dBm Input Power		24		dB
	3.5V/-0.5V bias, -25 dBm Input Power	18	24		
	4V/-0.5V bias, -25 dBm Input Power		23		
Input Return Loss	3V/-0.5V bias, -25 dBm Input Power		8		dB
Output Return Loss			9		
Noise Figure			6.5		
Reverse Isolation			45		
Bias Requirements ⁴	3V/-0.6V		130		mA
	3V/-0.5V		180		
	3V/-0.4V		230		
Input IP3 (IIP3)	3V/-0.5V bias, -25 dBm Input Power		3		dBm
Output IP3 (OIP3)			27		
P_{1dB}	3V/-0.5V bias		14.8		

³ Minimum test specifications are verified up to 44 GHz within an EVAL fixture due to the high insertion loss of the fixture above 45 GHz.

⁴ Bias conditions tested with no RF input power. See section 3.6 for DC current vs. RF power

3.6 Typical Performance Plots⁵

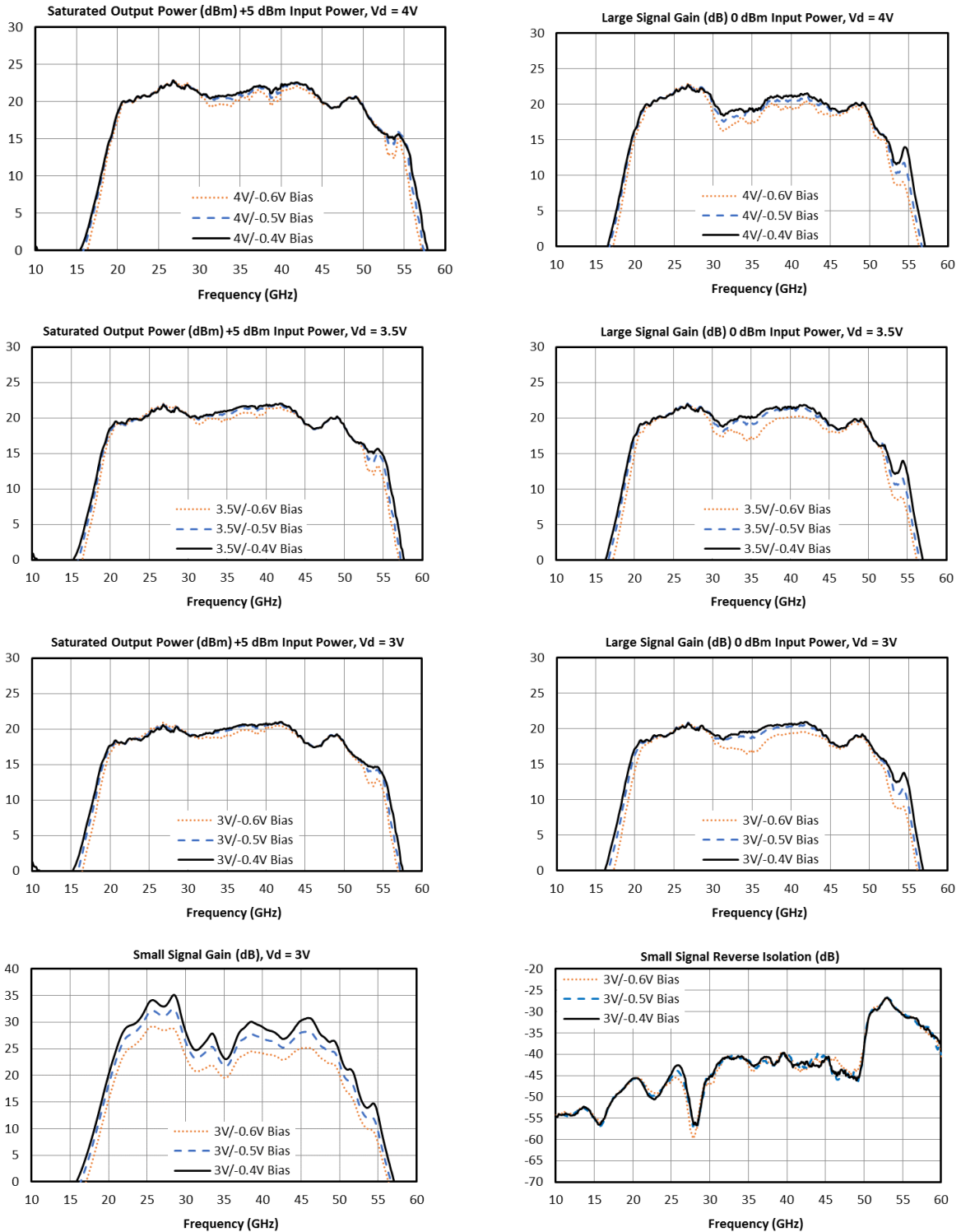

⁵ Measurement data extracted from within the EVAL-AMM-6702SM module. Insertion loss of the EVAL board has been extracted from the small signal gain and output power measurements.

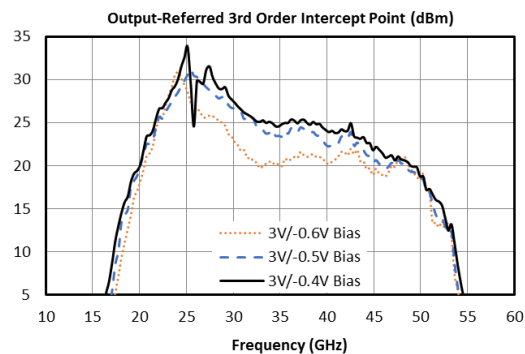
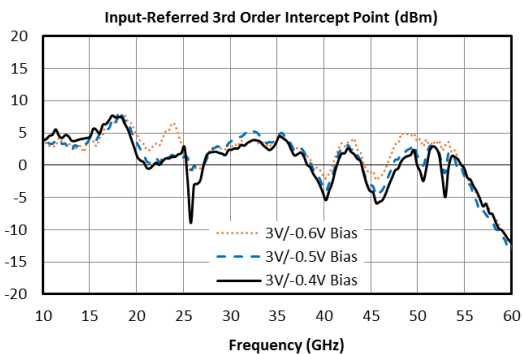
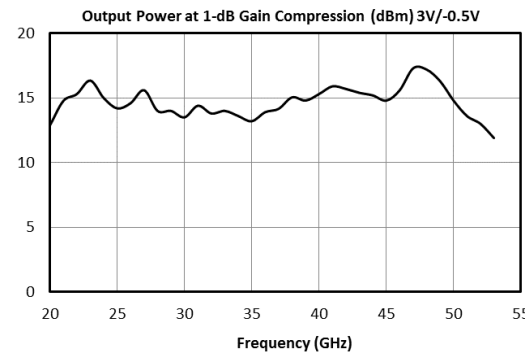
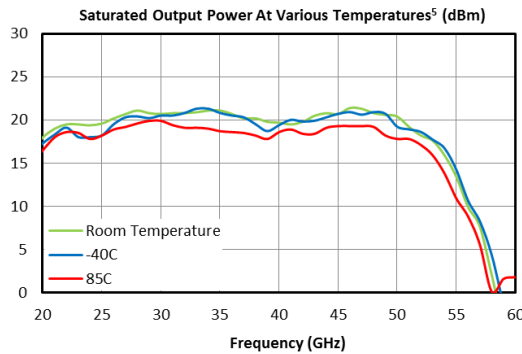
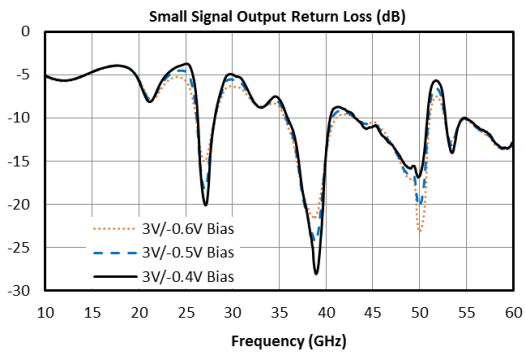
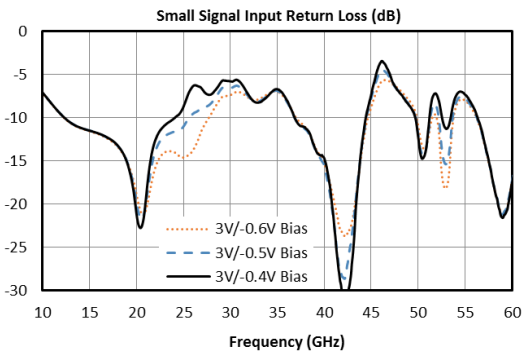
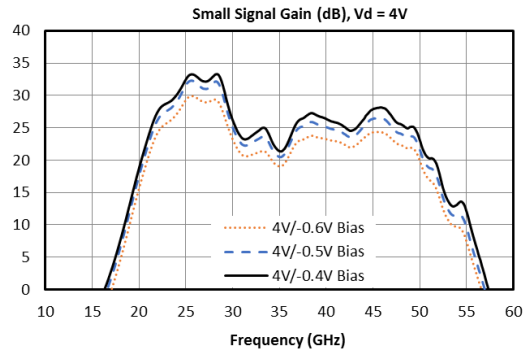
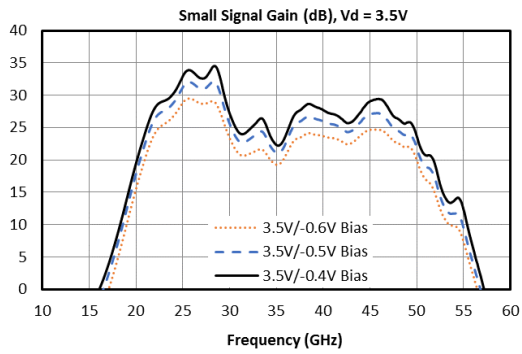

⁵ Temperature-controlled output power measurements were performed in the EVAL-AMM-6702SM test fixture with 3V/-0.5V bias and +10 dBm RF input power

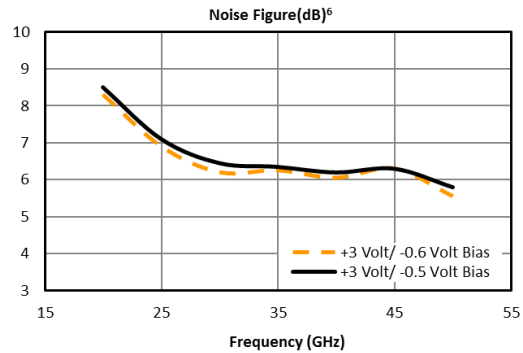
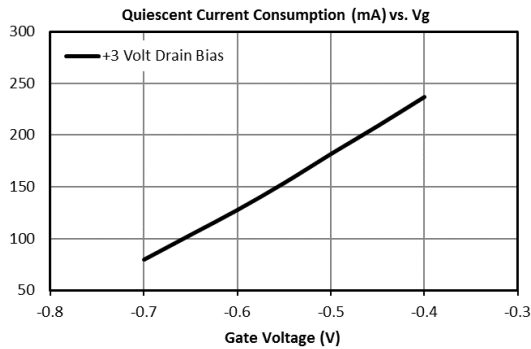
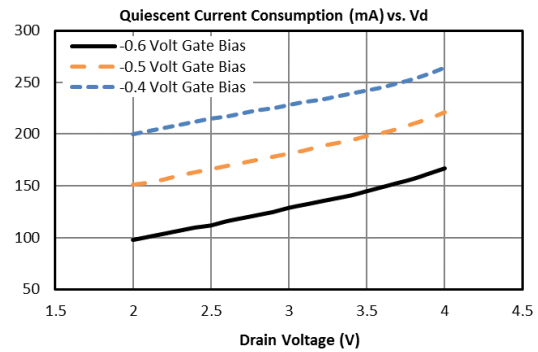
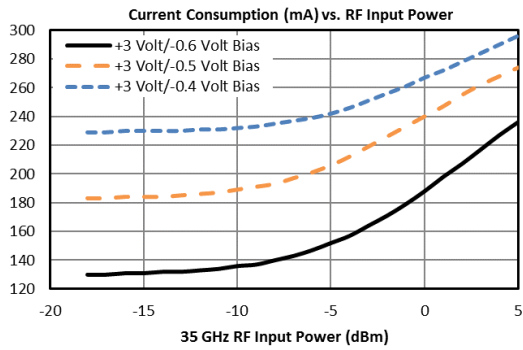

3.7 Conversion Loss of Marki Surface Mount Mixers Using AMM-6702SM as LO Driver⁷

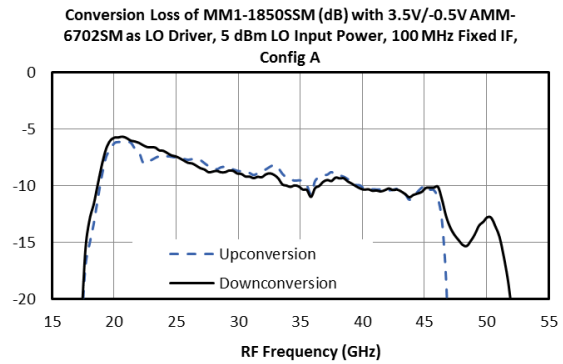
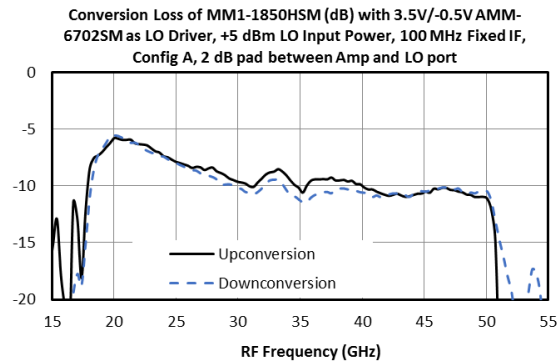

⁷ Conversion loss plots taken using custom AMM-6702SM/MM1-1850SM connectorized EVAL board. RF path insertion loss is ~1.5 dB at 50 GHz.

4. Application Information

4.1 Preventing oscillatory behavior

The AMM-6702SM contains a multi-stage MMIC amplifier with very high small signal gain. This MMIC can be susceptible to oscillatory behavior if it is mounted in an environment which allows for output power from the AMM-6702SM to radiate back to the DC drain voltage supply line. We have created a special ferritic KFN package to greatly reduce the susceptibility to this behavior, but oscillations are still possible if the environment is conducive to radiative feedback or cavity resonances.

The AMM-6702SM is designed to be driven in saturation/gain compression as an LO driver amplifier, and will be more susceptible to oscillations when driven in small signal operation. In the case that the amplifier oscillates in your application circuit, packing additional ferrite and absorber around the KFN is an effective tool to combat it. We advise our customers to experiment with the AMM-6702SM in their planned application circuit and to contact support@markimicrowave.com if they have any questions or need advice for avoiding oscillations.

The AMM-6702 has a potential oscillation if driven between -10 dBm and -8 dBm with a frequency between 22 GHz and 27 GHz with a Vd higher than 3.3V. If your application or frequency plan requires this specific condition, we advise that the user either reduce Vd or add an attenuator or pre-driver to the input to change the input power presented to the amplifier. The most stable condition to run this amplifier is in compression with at least 0 dBm to 5 dBm of input power.

4.2 Bypass Capacitance

It is recommended that customers use sufficient shunt capacitance to ground distributed along the gate and drain supply rails to prevent uncontrolled reactive loading from being presented to the DC supply ports of the AMM-6702SM. Customers observing oscillatory behavior in the amplifier may benefit from placing a small resistor in series with a large capacitor along the drain supply line close to the KFN.

4.3 Example Application Circuits

Below is an example of an application circuit using the AMM-6702SM to drive the LO port of an MM1-1850HSM. It is recommended that the customer use a small amount attenuation between the amplifier and the mixer to prevent a standing wave pattern from forming when using an MM1-1850HSM, which has a reflective LO port. There are bypass capacitors connected internally in the SM package, but we also recommend using additional surface mount capacitors on the drain and gate supply lines to ensure predictable performance. It is recommended to use 3.5-4V as +Vd to ensure sufficient output power through the middle of the band.

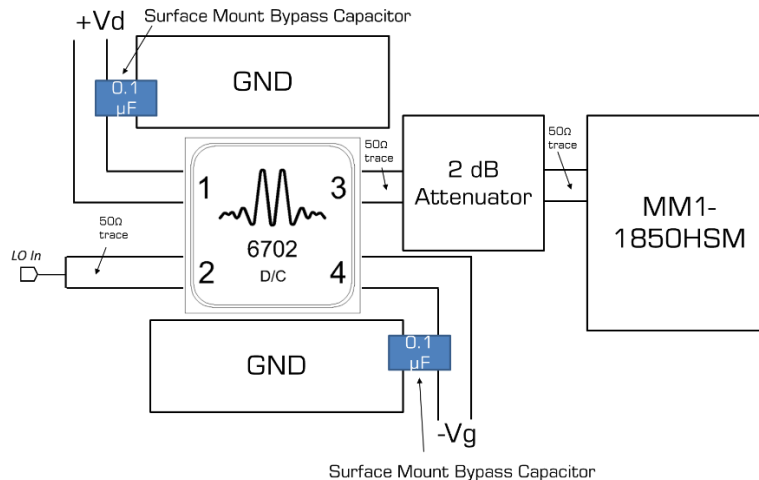

Below is an example of an application circuit using the AMM-6702SM to drive the LO port of an MM1-1850SSM. Note that in this case, the LO port of the mixer is not reflective, and the LO drive requirement is higher. Therefore, it is recommended that the amplifier output be fed directly into the LO port of the mixer rather than through an attenuator to ensure that sufficient LO drive reaches the mixer throughout the band. As in the previous example, it is recommended that the user apply 3.5 – 4V to the positive +Vd port to ensure high LO drive power.

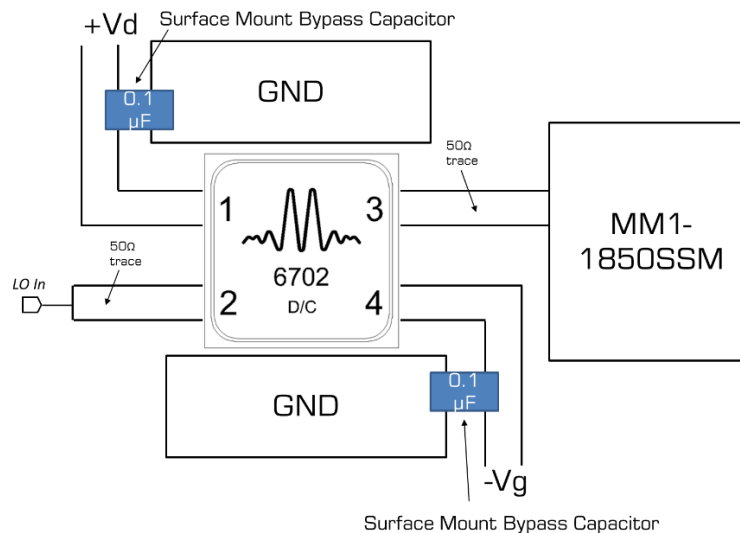

5. Mechanical Data

5.1 SMT Package Outline Drawing

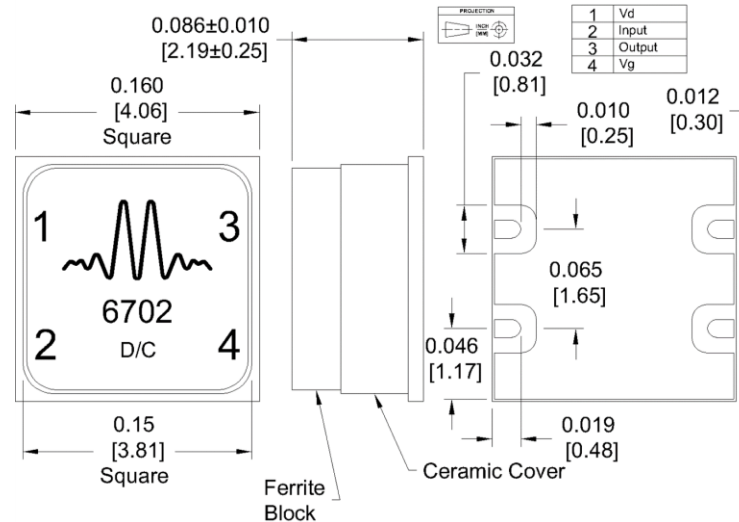

Notes:

- 1) Substrate and lid material is ceramic
- 2) I/O Leads and Ground Paddle plating is TiW/NiAu, 20 μ-inches max Au over 30 to 60 μ-inches Ni

5.2 AMM-6702SM Landing Pattern

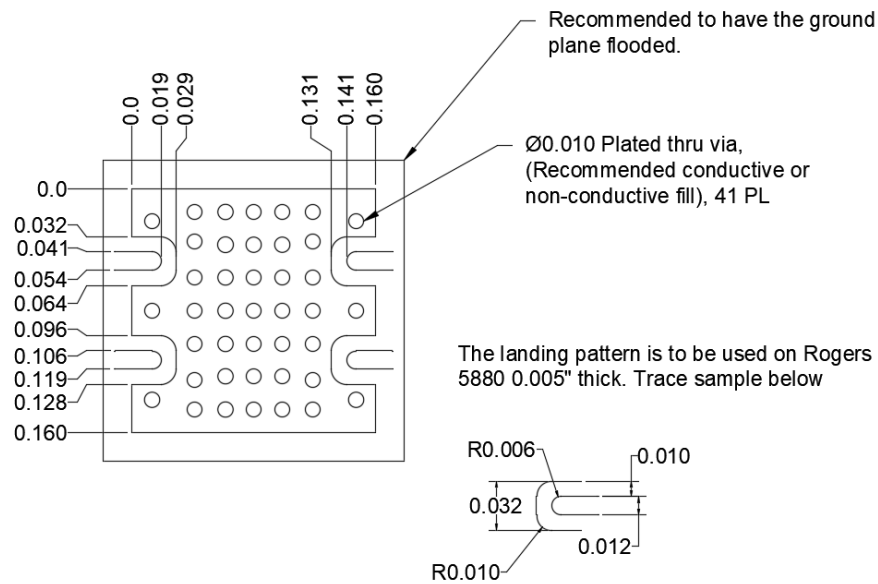

Landing pattern drawing: [AMM-6702SM Landing Pattern.dxf](#)

5.3 EVAL Package Outline Drawing

